

JLUCFZW6002

freezer

Instruction manual

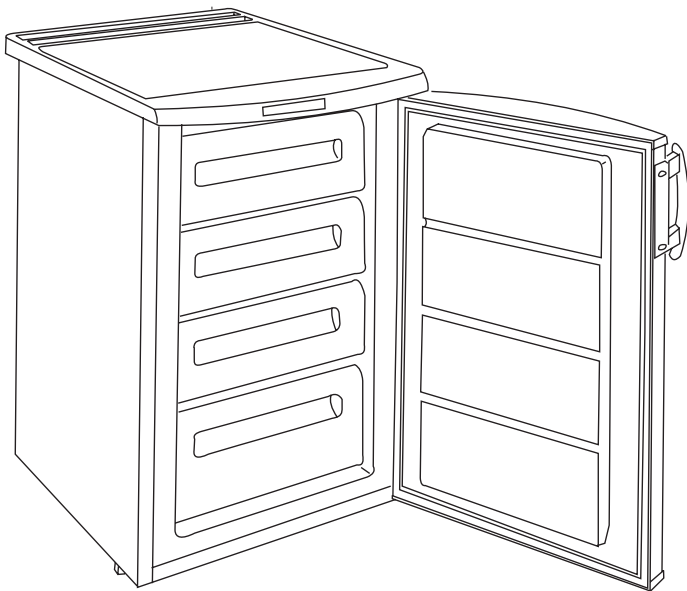

John Lewis

Important safety information

It is most important that this instruction book should be retained with the appliance for future reference. Should the appliance be sold or transferred to another owner, or should you move house and leave the appliance, always ensure that the book is supplied with the appliance in order that the new owner can get to know the functioning of the appliance and the relevant warnings.

These warnings have been provided in the interest of safety. You **MUST** read them carefully before installing or using the appliance.

If you are unsure of the meanings of these warnings contact the John Lewis branch from which you purchased the appliance.

Installation

- This appliance is heavy. Care should be taken when moving it.
- Check your Freezer for any transport damage. Do not connect the appliance if there is damaged. If the Freezer is damaged, you should contact the John Lewis branch from which you purchased it.
- Any electrical work required to install this appliance should be carried out by a qualified electrician or competent person.
- Care must be taken to ensure that the appliance does not stand on the electrical supply cable. If the supply cable is damaged it must be replaced; contact our extended warranty administrators on 08700 107 887 who will give you details for your local Service Force centre.
- Parts which heat up should not be exposed. Whenever possible, the back of the appliance should be close to a wall, but leaving the required distance for ventilation, as stated in the installation instructions.
- This appliance should be left for 2 hours after installation before it is turned on, in order to allow the refrigerant to settle.

Child Safety

- This appliance is designed to be operated by adults. Children should not be allowed to tamper with the controls or play with the product.
- Pets and children have been known to climb into the appliance. Please check the appliance before use.
- Keep all packaging well away from children.
- When the appliance is to be scrapped, cut off the electrical supply cable and destroy the plug with the remaining cable. Disable the door catch in order to prevent children from becoming trapped inside while playing

Use

- This appliance is designed for domestic use only, specifically for the storage of edible foodstuffs only. It is not intended for commercial or industrial use.
- Containers with flammable gases or liquids can leak at low temperatures. Do not store any containers with flammable materials, such as spray cans, fire extinguisher refill cartridges etc. in the refrigerator or the vicinity of the refrigerator or any other appliance.
- Frozen food should not be refrozen once it has thawed out.
- Do not place carbonated or fizzy drinks in the freezer compartment.

- Ice lollies can cause frost/freezer burns if consumed straight from the freezer compartment.
- Do not remove items from the Freezer if your hands are damp/wet, as this could cause skin abrasions or frost/freezer burns.
- Bottles and cans must not be placed in the Freezer as they can burst as the contents freeze.
- Manufacturers recommended food storage times should be adhered to. Refer to the relevant instructions.
- Do not use electrical appliances inside the Freezer.
- Store pre-packed frozen foods in accordance with the frozen foods instructions and use by date.
- When cleaning, defrosting, taking out frozen foods or ice tray do not use sharp, pointed or hard devices, as they can cause damage to the appliance.
- Do not damage the refrigerant circuit.

Safety precautions for isobutane

Warning

- The refrigerant of the appliance is isobutane (R600a) that is flammable and explosive to a greater extent.
- Keep ventilation openings, in the appliance enclosure or in the built-in structure, clear of obstruction.
- Do not use mechanical devices or other means to accelerate the defrosting process, other than those recommended by the manufacturer.
- Do not damage the refrigerant circuit.
- Do not use electrical appliances inside the food storage compartments of the appliance, unless they are of the type recommended by the manufacturer.

For the safety of life and property keep the precautions of these user's instructions as the manufacturer is not responsible for damages caused by omission.

Maintenance and Cleaning

- Before cleaning, always switch off the appliance and disconnect from the electrical supply, when unplugging always pull the plug from the mains socket, do not pull on the cable.
- Further information on cleaning is on page 15 of this manual.

Service

- This product should only be serviced by an authorised engineer and only genuine spare parts should be used.
- Under no circumstances should you attempt to repair the appliance yourself. repairs carried out by inexperienced persons may cause injury or serious malfunction.
- Service Force are the authorised repair agents for John Lewis branded domestic appliances.



Ecological Hints

To save energy and help protect the environment, we recommend that you follow these hints.

- Do not install the appliance close to sources of heat such as a boiler or radiator.
locate the appliance in a well ventilated room and make sure that any air openings of the appliance are not obstructed.
- Pack all foods into airtight packages before placing them into the freezer compartment.
Food which is to be frozen (when cool) should be placed in the fridge compartment before being transferred to the freezer.
try to avoid keeping the door open for long periods or opening the door too frequently as warm air will enter the cabinet and cause the compressor to switch on unnecessarily often.
- Ensure there are no obstructions preventing the door from closing properly.



Environmental Information

After unpacking please dispose of the packaging with due regard to safety and the environment.

Materials marked with the symbol  are recyclable.

Avoid damaging the cooling unit, especially at the rear near the heat exchanger. Check with your local Council or Environmental Health Office to see if there are facilities in your area for recycling this appliance.

When the appliance is to be scrapped, cut off the power supply cable and remove the door, to prevent young children from being trapped inside.

This appliance does not contain gases which could damage the ozone layer, in either its refrigerant circuit or insulation materials.



Warning

A cut off plug inserted into a 13 amp socket is a serious safety (shock) hazard. please ensure the cut off plug is disposed of safely.

The symbol  on the product or on its packaging indicates that this product may not be treated as household waste.

Instead it shall be handed over to the applicable collection point for the recycling of electrical and electronic equipment. By ensuring this product is disposed of correctly, you will help prevent potential negative consequences for the environment and human health, which could otherwise be caused by inappropriate waste handling of this product. For more detailed information about recycling of this product, please contact your local city office, your household waste disposal service or the shop where you purchased the product.

Contents

For the User

Important safety information 2

Intallation 2

Description of the appliance 5

Using the freezer 11

Switch and indicators 11

Basket storage 11

Operation and use 11

Installation 11

Adjusting the temperature 11

Freezing 12

Freezing and storage of frozen foods 12

Thawing 12

How to make ice cubes 12

Hints & Tips 13

Food Storage 13

Normal Operating Sounds 13

In the Event of a Power Failure 13

Storage time chart 14

Maintenance and Cleaning 15

Long-term absence 15

Automatic defrosting 15

No-Frost technology 15

Internal cleaning 15

External cleaning 15

When the appliance is not in use 15

Something Not Working 16

Repairs - After Sales Service 17

For the Installer

Installation 6

Technical Specifications 6

Unpacking 7

Cleaning 7

Location 7

Climate Classification 7

Ventilation Requirements 7

Door Reserval 8

Electrical connection 9

When the freezer is first installed 10

General information 10

Using the Appliance 10

Before Use 10

Guide to using the Instruction Manual

The following symbols will be found in the text to guide you throughout the instructions:

 Safety precautions

 Hints, useful information

 Environmental information

 This appliance complies with the following E.E.C. Directives:

- 73/23 EEC of 19.02.73 (Low Voltage Directive) and subsequent modifications,
- 89/336 EEC of 03.05.89 (Electromagnetic Compatibility Directive) and subsequent modifications.

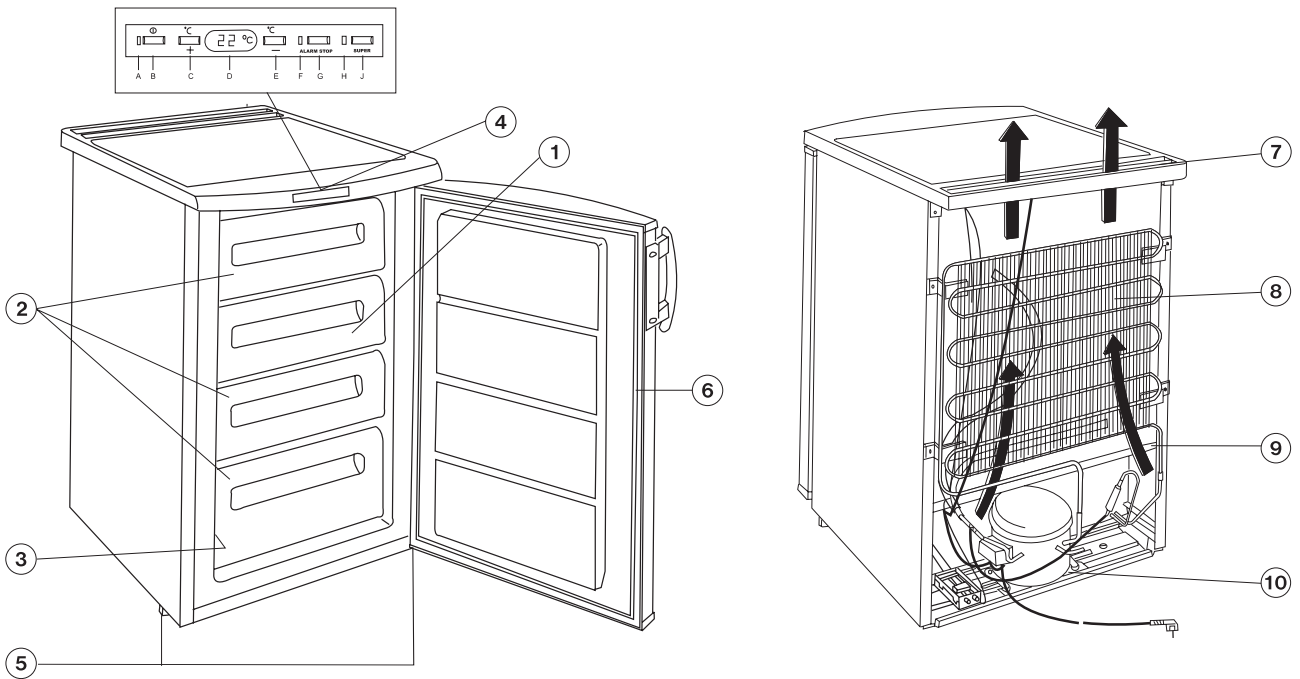

Description of the appliance



1. Freezing compartment
2. Freezer (baskets)
3. Data plate
4. Switches and indicators
5. Adjustable feet

6. Door sealing gasket
7. Ventilation grid
8. Condenser
9. Airflow direction
10. Compressor

Installation

-  It is dangerous to alter the specifications or attempt to modify this product in any way.
-  Care must be taken to ensure that the appliance does not stand on the electrical supply cable.
-  Any electrical work required to install this appliance should be carried out by a qualified electrician or competent person.

Technical Specifications

DIMENSIONS	Width Height Depth	595 mm 850 mm 635 mm
POWER SUPPLY VOLTAGE		230V/50Hz
RATED CURRENT		0,5 A
GROSS CAPACITY		100 l
NET CAPACITY		80 l
FREEZING CAPACITY		9 kg/24 h
ENERGY CONSUMPTION		0,575 kWh/24h 210 kWh/year
ENERGY CLASS, ACCORDING TO EU STANDARDS		A
RISING TIME		13 h
WEIGHT		40 kg

Unpacking

i The appliance should be delivered in its original packaging; the appliance must always be kept in a vertical position as indicated by the warnings on the packaging.

After each transportation the appliance must not be switched on for approximately 2 hours. This allows the coolant gases to settle.

After unpacking the appliance, check to see if there is any damage. If there is damage to the appliance you should contact the John Lewis branch from which you purchased it. In that case retain the packaging.

Cleaning

Remove all adhesive tape and internal packaging.

Wash the inside of the appliance using lukewarm water and mild detergent. Use soft cloth.

After cleaning wipe out the inside of the appliance.

Location

The appliance should be positioned in a well ventilated, dry room.

Energy use is affected by the ambient temperature.

The appliance should therefore:

- not be installed next to radiators, cookers or other sources of heat
- only be installed at a location where the ambient temperature corresponds to the climate classification, for which the appliance is designed.

Climate Classification

The climate classification can be found on the serial plate.

The following table shows which ambient temperature is correct for each climate classification:

Climate Classification	Ambient Temperature
SN	+10 to +32 °C
N	+16 to +32 °C
ST	+18 to +38 °C

Ventilation Requirements

The appliance must have adequate ventilation to ensure correct operation.

Diagram shows the ventilation requirements when installed:

A: Under a worktop, or cupboard.

The clearance space of 10 cm above the appliance may be reduced to 5 cm providing a clearance space 2,5 cm is left on either side of the appliance.

B: When freestanding

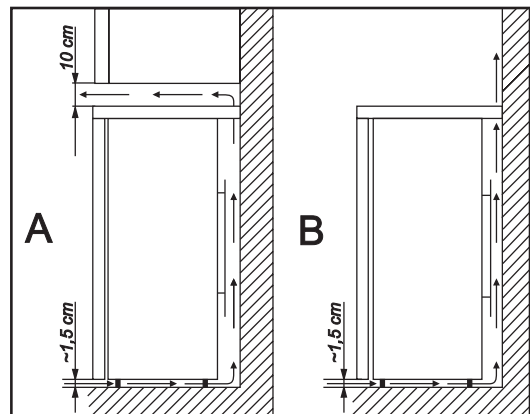

Door Reversal

If required the door can be reversed, hinged from the left, opening from the right.

To reverse the bottom hinge assembly proceed as follows:

- Disconnect the appliance from the electricity supply.
- Tilt the appliance backwards, resting the top edge of the appliance on a stool or something similar.
- Unscrew the 2 adjustable feet. Unscrew the 3 screws holding the lower door bracket. transfer the lower door hinge pin to the alternative position as shown in the top drawing. Unscrew the single screw at the bottom left hand side and retain . Replace the lower door bracket on the bottom left hand side but do not fully tighten the 3 screws.

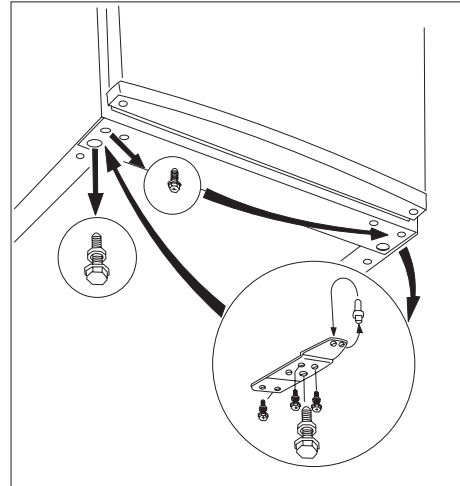

- Remove the fridge door by gently pulling downwards and store to avoid damage.
- Unscrew the top door hinge pin of the refrigerator then screw it back on the other side. As shown in the second drawing.
- Replace the fridge door on the upper door hinge pin.
- Insert the lower door hinge pin into the door and tighten all screws.
- Re-fix the retained screw to the bottom right hand side and replace the 2 adjustable feet.
- Lift the fridge back onto its feet and check it is set level and the door seal meets the fridge all around the door.

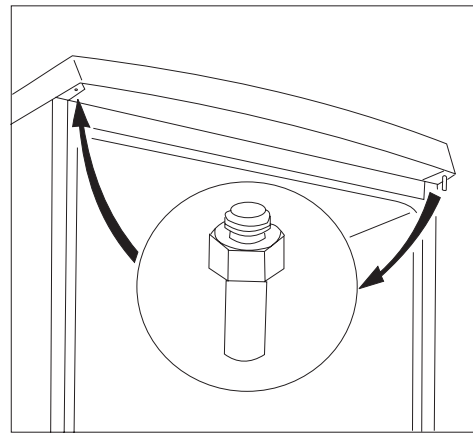

- Transfer the handle to the opposite side and place the plastic covering inserts, (supplied in the plastic bag of this instruction book) into the holes set free.
- Reconnect the fridge to the electricity supply.

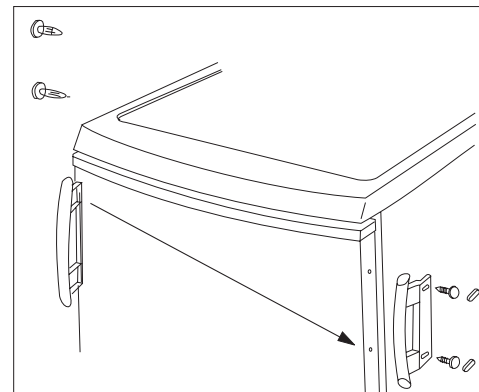

Electrical connection

Any electrical work required to install this appliance should be carried out by a qualified electrician or competent person.

⚠ WARNING: THIS APPLIANCE MUST BE EARTHED.

Should the appliance power supply cable need to be replaced, this must be carried out by a Service Force agent (see page 17).

The manufacturer declines any liability should this safety measure not be observed.

Before switching on, make sure the electricity supply voltage is the same as that indicated on the appliance's rating plate. (See picture on page 5).

The appliance is supplied with a 13amp plug supplied. In the event of having to change the fuse in the plug supplied, a 13amp ASTA approved BS 1363/A fuse must be used.

Should the plug need to be replaced for any reason, proceed as described below. The wires in the mains lead are coloured in accordance with the following code:

Green and Yellow	- Earth
Blue	- Neutral
Brown	- Live

If you fit your own plug, the colours of the wires in the mains lead of your appliance may not correspond with the markings identifying the terminals in your plug.

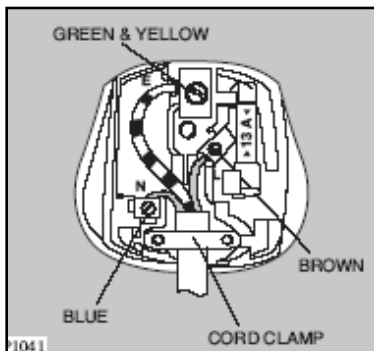

Proceed as follows:

1. Connect the Green and Yellow (earth) wire to the terminal in the plug which is marked with the letter "E" or the earth symbol (⊕) or coloured green and yellow.
2. Connect the Blue (neutral) wire to the terminal in the plug which is marked with the letter "N" or coloured black.
3. Connect the Brown (live) wire to the terminal in the plug which is marked with the letter "L" or coloured red.
4. Upon completion there must be no cut, or stray strands of wire present and the cord clamp must be secured over the outer sheath.

⚠ WARNING: A cut off plug inserted into a 13 amp socket is a serious safety (shock) hazard. Ensure that the cut off plug is disposed of safely.

⚠ The plug must still be accessible after the appliance has been installed.

⚠ The appliance should not be connected to the electrical supply by means of an extension cable.

Permanent connection

In the case of permanent connection it is necessary that you install a double pole switch between the appliance and the electricity supply (mains), with a minimum gap of 3mm between the switch contacts and of a type suitable for the required load in compliance with the current electrical regulations.

The switch must not break the yellow and green earth cable at any point.

When the freezer is first installed

General information

This appliance is designed for the freezing and storage of frozen food in a domestic home.

To ensure correct operation, the appliance should be located where the ambient temperature is between 16-32 °C.

Using the Appliance

Before Use



The freezer must be thoroughly cleaned before use; see page 15.



To Start the Appliance

Insert the plug into the socket. Press the on/off switch of the freezing compartment. The green on/off indicator will light continuously and the current temperature value will flash.

The flashing of the red alarm indicator and the acoustic alarm will warn you that the internal temperature is not yet sufficient for the conservation of food. To switch off the acoustic alarm and the temperature display flashing, press button "G". Do not put any food in the freezer until the internal temperature reaches -18 C or the red alarm indicator goes out.

Using the freezer

Switches and indicators

- A) On/off indicator green
- B) On/off switch
- C) Thermostat button (for higher temperatures)
- D) Temperature display
- E) Thermostat button (for lower temperatures)
- F) Alarm indicator red
- G) ACOUSTIC alarm OFF switch
- (see "Control and information system")
- H) QUICK FREEZE indicator yellow
- J) QUICK FREEZE pushbutton switch

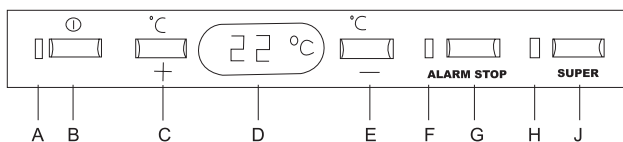

Basket Storage

Frozen food should be stored in the freezer baskets and the second compartment used for storage or fast freezing of fresh food.

Operation and use

Installation

Insert the plug into the socket. Press the on/off switch of the freezing compartment. The green on/off indicator will light continuously and the current temperature value will flash.

The flashing of the red alarm indicator and the acoustic alarm will warn you that the internal temperature is not yet sufficient for the conservation of food. To switch off the acoustic alarm and the temperature display flashing, press button "G". Do not put any food in the freezer until the internal temperature reaches -18 C or the red alarm indicator goes out.

Adjusting the temperature

Temperature controls

Temperature can be regulated with the use of the "+" (higher) and "-" (lower) buttons.

These buttons are interlinked with the temperature display.

- Press either "+" or "-" to switch the temperature display from CURRENT temperature (continuous lighting) to DESIRED temperature (flashing).
- If neither button is pressed again, the temperature display will shortly (within approx. 5 seconds) return to CURRENT temperature.

DESIRED temperature:

It is the temperature to be achieved in the freezing compartment.

CURRENT temperature:

It is the actual temperature of the freezing compartment as shown on the temperature display. The CURRENT temperature is shown by a continuous light.

Temperature display

The temperature display is able to show various information:

- Under normal operating conditions it displays the actual temperature (CURRENT temperature) of the freezer.
- At the time of setting the temperature, the freshly set temperature (DESIRED temperature) will flash.

QUICK FREEZE on/off switch

The quick freeze function ("FROSTMATIC") is used to achieve the quick freezing of fresh food and to prevent the already frozen goods from undesirable warming up. You can turn on the quick freeze function by pressing the quick freeze on/off switch. The yellow indicator will light up.

You can manually turn off the quick freeze function any time by pressing the quick freeze on/off switch again. The yellow indicator will go out. If not switched off manually, the quick freeze function will be automatically switched off 48 hours later. The yellow indicator will go out.

Temperature problem

Once the temperature of the freezing compartment rises above -12 C the red alarm indicator will light up and an acoustic alarm will be heard.

Possible causes of such temperature rise:

- door opened too frequently or left open too long
- large volume of hot food stored in the freezing compartment
- product defect.

You can stop the acoustic alarm by pressing the "Acoustic alarm off switch". Once the temperature of the freezing compartment reduces to a displayable value, the red alarm indicator and the acoustic alarm will automatically stop.

Note:

The acoustic alarm will stop:

- when the quick freeze function is switched on (by pressing the "Quick freeze on/off switch")

Freezing

Prepare the various foods properly and then freeze them always in the freezing compartment.

The quick freeze function ("FROSTMATIC") is used to achieve the quick freezing of fresh food and to prevent the already frozen goods from undesirable warming up.

For using the quick freeze function, press the quick freeze on/off switch **(J)** for 2-3 seconds; in the case of small and great food volumes you should do it approx. 4 and 24 hours, respectively, before you want to freeze the fresh food.

The yellow indicator **(H)** will light up and the compressor will operate continuously until the product reaches the freezing temperature.

Once the food is completely frozen (it may take up to 24 hours) you can manually switch off the quick freeze function by pressing the switch **(J)** for 2-3 seconds. If not switched off manually, the quick freeze function will be automatically switched off 48 hours later. The yellow indicator **(H)** will also go out.

Freezing and storage of frozen foods

- As freezing with "No-Frost" technology is quicker, the foods frozen this way will preserve their original form, nutritional value and taste even after thawing.
- Place the foods to be frozen in the second part of the product.
- For the best operation of the product, make sure that the frozen foods will not touch the ventilator cover or the ventilator mounted on the backside of the product.
- For the best results it is recommended to distribute the frozen foods evenly in the boxes.
- If you make small portions of the foods, the freezing process will take less time and subsequent thawing will be possible in small portions also.
- In order to avoid freezing burns, do not touch ice-creams immediately after they have been taken out from the freezer.
- It is recommended to state the freezing date on the package so that later you can check the storage duration.
- The time of transportation from the seller to the consumer must be as short as possible.

Thawing

Deep frozen or frozen food, prior to being used, can be thawed in a fridge or at room temperature, depending on the time available. Small food items may even be cooked from frozen, in this case cooking will take longer.

Any frozen food which is allowed to thaw accidentally should either be eaten as soon as possible, or thrown away. Alternatively, if the food is uncooked and has not been completely defrosted it can be cooked and then refrozen.



Defrosted cooked food must never be refrozen.

How to make ice cubes

Fill the supplied ice cube tray $\frac{3}{4}$ full with water and place in the freezer compartment. Turning up the thermostat control will speed up the freezing process, but remember to turn the thermostat control back to its original position.

To release the ice cubes, twist the tray along its length.

Do not use sharp or pointed items to remove a frozen ice cube tray from the freezer compartment.

Hints & Tips

In this chapter practical hints and ideas are given about how to use the appliance to reach maximum energy saving and there is environmental information about the appliance as well.

Normal Operating Sounds

- You may hear faint gurgling or bubbling sounds when the refrigerant is pumped through the coils or tubing.
- When the compressor is on, the refrigerant is being pumped round and you will hear a whirring sound or pulsating noise from the compressor.
- A thermostat controls the compressor and you will hear a faint 'click' when the thermostat cuts in and out.

Food Storage

To obtain the best performance from your appliance:

- Do not store warm food or evaporating liquid.
- Avoid buying frozen food if you cannot store it straight away. The use of an insulated container is advisable. When you arrive home, place the frozen food in the Freezer immediately.
- Do not push food together too much.
- Do not store food uncovered.
- Ensure that food placed in the Freezer is dated and labelled and used in date order to ensure that food is consumed at its best.
- Lean food keeps better and longer than fatty food, salt reduces the storage time.
- Wrap the food in polythene or aluminium freezing bags or foil so that they adhere to the food and provide an airtight seal.
- Packaging which is swollen or has traces of refrozen water droplets on the pack could indicate that the product has not been kept at a suitable temperature and that it may have lost its original quality. Partially thawed food must not be refrozen, it must be consumed within 24 hours. Never exceed the storage times indicated by the manufacturer.

In the Event of a Power Failure

If there is a power failure during the storage of frozen foods, keep the door closed. If the temperature within your Freezer should rise, do not refreeze the food without checking its condition. The following guidelines should assist you:

Ice Cream: Once thawed should be discarded.

Fruits & Vegetables: If soft should be cooked and used up.

Breads & Cakes: Can be refrozen without danger.

Shellfish: Should be refrigerated and used up quickly.

Cooked Dishes: i.e. casseroles should be refrigerated and used up.

Large Pieces of Meat: Can be refrozen providing there are still ice crystals remaining within them.

Small Joints: Should be cooked and can then be refrozen as cooked dishes.

Chicken: Should also be cooked and refrozen as a fresh dish.

Storage time chart

Storage time of deep-frozen and frozen products

Foods	-18°C
Vegetables: green beans, green peas, mixed vegetables, marrow, corn, etc.	12 months
Ready-cooked foods: vegetable dish, trimmings, with meat, etc.	12 months
Ready-cooked foods: sirloin steaks,	6 months
Foods from potatoes, pasta: mashed potato, gnocchi, dumpling, filled pasta	12 months
Soups: vegetable soup	6 months
Fruits cherries	12 months
Meat: chicken, duck, goose	5 months
fillets, tuna fish	6 months
Ice-cream	3 weeks

Maintenance and Cleaning

 Before any maintenance or cleaning work is carried out **DISCONNECT** the appliance from the **ELECTRICITY SUPPLY**.

Long-term absence

If you do not use the product for long periods, make sure to perform the following:

Set the thermostat to position << ● >>.

Disconnect the product from the mains.

Remove all foods from the product.

Perform defrosting and cleaning operations as described above.

Leave the doors ajar to avoid the build-up of unpleasant odors.

Automatic defrosting

This product is designed to avoid the formation of ice in the freezer. Accordingly, there is no need for manual defrosting. The product will automatically perform any defrosting once it becomes necessary.

No-Frost technology

In order to facilitate the removal of the ice layer, the evaporator is assisted by electric heating during the defrosting procedure. The ventilator is in OFF position. The defrost water will drip in the tray placed at the compressor and will evaporate. In the course of the defrosting procedure (approx. 30 minutes) the evaporator becomes warm but it has no influence on the internal temperature.

The foods should be kept well-packed in order to avoid any moisture loss as a result of air circulation.

Do not obstruct the vent holes because otherwise the operation of the product may be compromised.

For such purpose it is recommended to put all foods in the baskets in the freezer compartment.

Internal Cleaning

Clean the inside and accessories with warm water and bicarbonate of soda (5 ml to 0.5 litre of water). Rinse and dry thoroughly.

 Do not use detergents, abrasive powders, highly perfumed cleaning products, wax polishes or cleaning products containing bleach or alcohol.

 Regularly check the door seals and wipe clean to ensure they are clean and free from debris.

External Cleaning

Wash the outer cabinet with warm soapy water.

Once or twice a year dust the condenser (black grill) and the compressor at the back of the appliance with a brush or vacuum cleaner; as an accumulation of dust will affect the performance of the appliance and cause excessive electricity consumption.

When the appliance is not in use

When the appliance is not in use for long periods disconnect from the electricity supply, empty all of the food and clean the appliance, leaving the door ajar to prevent unpleasant smells.

Something Not Working

If the refrigerator is not working correctly, please carry out the following checks before contacting your local Service Force agent.

IMPORTANT: If you call out an engineer to a fault listed below, or to repair a fault caused by incorrect use or installation, a charge will be made even if the appliance is under guarantee.

Symptom	Solution
No power to the appliance	<ul style="list-style-type: none">• Check there is power at the socket.• Check there is not a power cut by checking the household lights.• Check the fuse has not blown.• Press the on/off switch (B) for more than a second.
The temperature in the appliance is too high	<ul style="list-style-type: none">• Check the ambient temperature is within the appliances operating limits of 16 °C to 32 °C.• Check that the thermostat control knob is turned to the correct setting relative to ambient conditions.
The temperature in the appliance is too low	<ul style="list-style-type: none">• Set the thermostat control knob to a lower position.
Excessive frost and ice has built up	<ul style="list-style-type: none">• Check the door has not been left open.• Check nothing is preventing the door from closing.• Check the door gasket is intact and clean.
The appliance is noisy.	<ul style="list-style-type: none">• Check if the appliance stands stable (all four feet should be on the floor).

Power or operation failure:

In case of power failure during the storage of frozen foods, make sure not to open the freezer door. Once the power failure is over, the yellow indicator (3) of the quick freeze function will light up and then, 5 hours after restart, it will automatically go out.

If a short power failure occurs (max. 13 hours) and the product is full, the stored foods will not deteriorate. Otherwise you must use the stored food as soon as possible (if the temperature of the frozen foods rises, their storability will be shorter).

When the electronic system fails to detect the ACTUAL temperature, the alarm indicator will start to flash. The product will continue to operate with the use of a reserve system until the problem is eliminated by the local service personnel.

Repairs - After Sales Service

In the unlikely event of your appliance requiring service, or if you wish to purchase spare parts, please contact our extended warranty administrators by telephoning:

0870 010 7887

They will give you details for your local Service Force Centre.

Before calling out an engineer, please ensure you have read the details under the heading "Something Not Working".

When you contact your local Service Force Centre you will need to give the following details:

1. Your name, address and post code
2. Your telephone number
3. Clear and concise details of fault
4. The purchase date found on your receipt.
5. The model and serial number of the appliance (found on the rating plate - see picture on page 5)

So that you always have these numbers at hand, we recommend you to make a note of them here:

Mod. :.....

PNC :.....

S.N. :.....

Your Fridge - Freezer is covered by a 3 year parts and labour guarantee (see separate details given at point of sale). Please retain your purchase receipt safely for the service engineer to verify the purchase details.

Spare parts

Always insist on genuine spare parts. An authorised service engineer should service this product, and only genuine spare parts should be used. Under no circumstances should you attempt to repair the machine yourself. Repairs carried out by inexperienced persons may cause injury or serious malfunctioning. Contact your local Service Force Centre. An authorised service engineer always insist on genuine spare parts.

John Lewis Partnership
171 Victoria Street
London SW1E 5NN

www.johnlewis.com